

KEYBOARD INSTALLATION

Sept 13, 2000
P/N: 20124-01

TOOLS REQUIRED:

Power Driver
#2 Phillips Head Bit
#3 Phillips Head Bit

NOTICE: TO INSTALLER

When installing with systems products, leave 1" clearance between edge of adjustable surface and edge of adjacent work surface and panel or wall to prevent pinch hazards.

PROCEDURE:

1. Place monitor and keyboard surfaces upside down on clean padded surface. Mount keyboard arm to monitor surface aligning holes using (2) #12 x 1¹/₈" pan head screws on the left side and (4) on the right side, using power driver. (See Figure 1). Call Customer Service if hole pattern is needed.
2. Mount keyboard arm to keyboard surface aligning holes using (2) #12 x 1 1/8" pan head screws on each side.
3. Insert keyboard brake release in slot on the right hand side of the keyboard top. Secure with (2) #8 x 3/4" pan head screws. (See Figure 2).
4. Place (1) plastic cable retainer on cable, approximately 1" behind release handle and secure with (1) #8 x 3/4" pan head screw.
5. If necessary, form a loop with excess cable from keyboard brake release and secure with plastic cable retainer and (1) #8 x 3/4" pan head screw. (See Figure 2).
6. Mouse retainer is optional and is normally installed on the back of the keyboard surface. The mouse retainer is a press fit or can be attached using (2) #8 x 1/2" pan head screws. (See Figure 3).

If any problems are experienced, please call Baker Manufacturing Customer Service at 888-512-7036.



ZYDECO *It Moves*

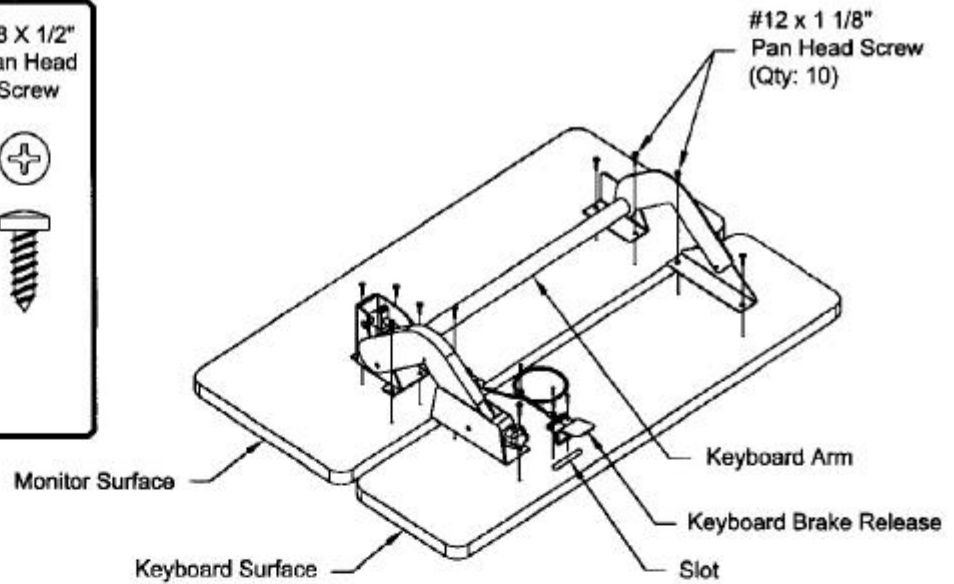
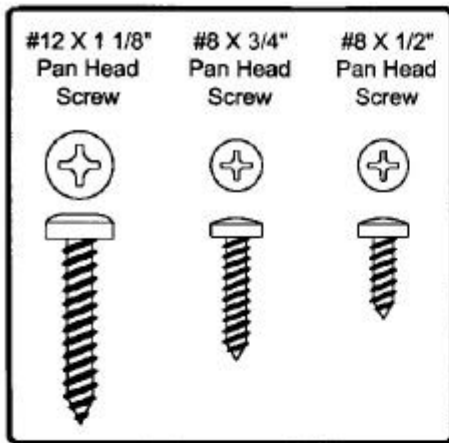

FIGURE 1

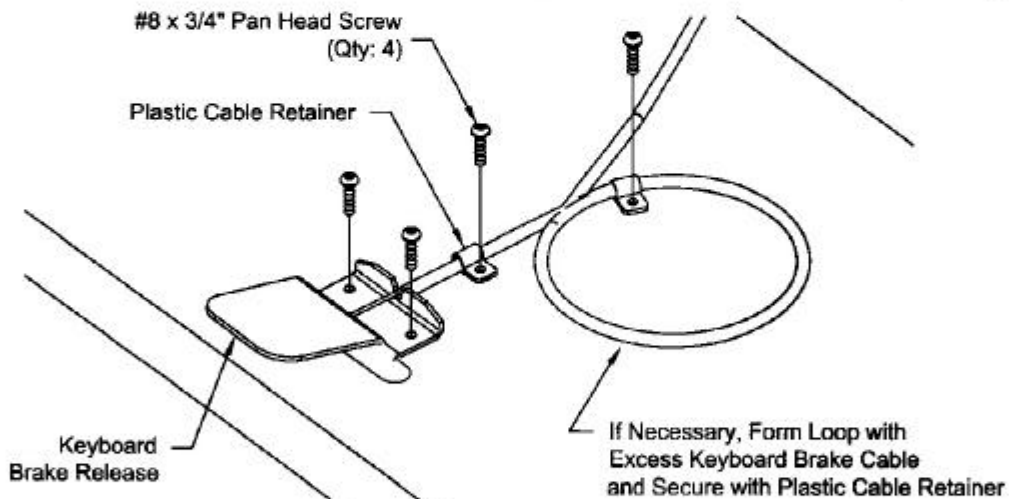

FIGURE 2

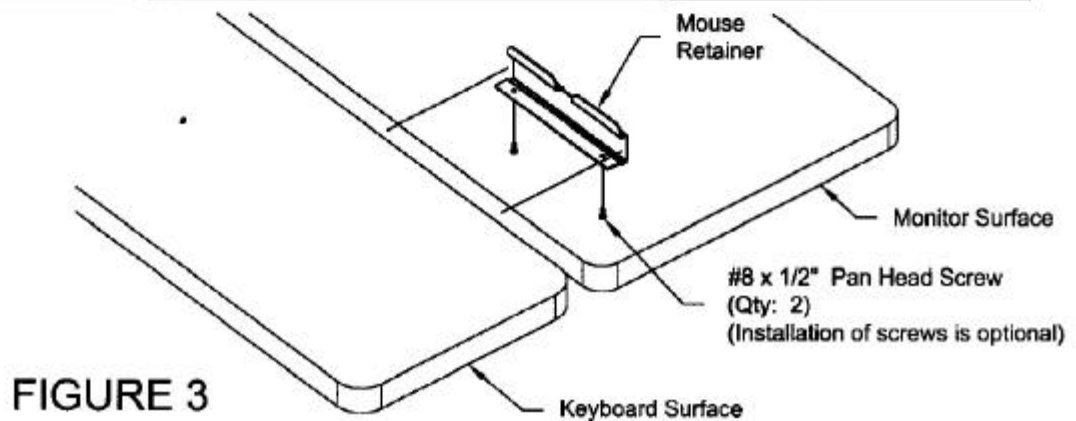

FIGURE 3